



# TempStar™ HH/GPX

Project \_\_\_\_\_  
 Item \_\_\_\_\_  
 Quantity \_\_\_\_\_  
 CSI Section 11400 \_\_\_\_\_  
 Approval \_\_\_\_\_  
 Date \_\_\_\_\_

## Models

TempStar™ HH/GPX



## Standard Features

- Multi-cycle timer (Extra Heavy, Heavy, Medium, Normal)
- Built-in pressure regulator and gauge
- Extended 15 second high temperature rinse provides superior coverage and rapid drying
- 20 3/4" (527 mm) wide X 27" (686 mm) high opening accommodates 18" (457 mm) X 26" (660 mm) sheet pans and 60 quart mixing bowls
- Auto-fill / auto-start
- Safety door switch
- External gas booster heater
  - Capable of minimum 70°F (21°C) degree temperature rise
  - Recirculates water through stainless steel coils in wash tank to maintain 150°F (66°C) degree minimum temperature
- Hi-limit thermostat and low water protection
- Top mounted controls for ease of installation
- Unique lower counter-rotating wash arms and upper wash arm provide optimum spray coverage and superior cleaning action
- Unique split-door design for installations with low ceiling heights
- Large scrap tray
- Self-draining stainless steel pump
- Detergent/rinse additive signal connection fuse box

- Delime/manual wash switch
- Adjustable bullet feet
- Uses standard 20" X 20" (508 mm X 508 mm) racks
- Front dress panel

## Mandatory Specs

- Specify incoming water temperature
- Specify how far booster will be placed from unit
- Specify altitude for proper booster size

## Optional Features

- Water hammer arrestor
- Flanged feet
- Drain quench system
- Scaltrol

## Accessories

- 36" (914 mm) compartment rack 4 1/6" (4 mm) tall
- 36" (914 mm) compartment rack 5 5/8" (16 mm) tall
- 36" (914 mm) compartment rack 7" (178 mm) tall
- Combination rack
- Peg rack
- Sheet pan rack 18" X 26" / (457 mm X 660 mm) baking pans

## Specifications

Uses 1.36 gallons (5 liters) of 180°F (82°C) water per rack

Total automatic normal cycle - 62 seconds

53 racks per hour normal cycle

2HP Wash Pump Motor

Single Point connections for all utilities

Built-in water pressure regulator and pressure gauge

Field convertible from straight through to corner operations

Heavy duty stainless steel construction



Highway 25E  
P. O. Box 1060  
Barbourville, KY 40906

Tel: 606-523-9795  
Tel: 1-888-800-5672  
Fax: 606-523-9196  
E-mail: info@jacksonmsc.com

www.jacksonmsc.com  
07610-002-66-62 (09/07)



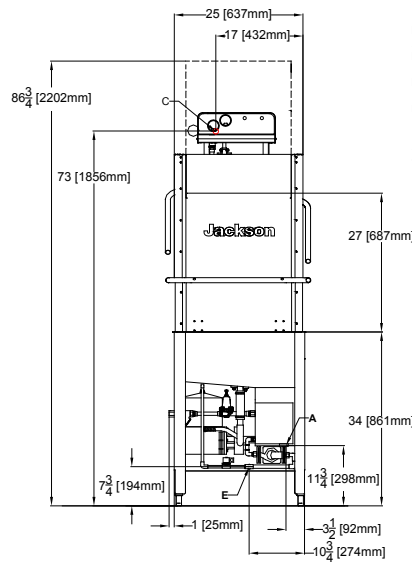
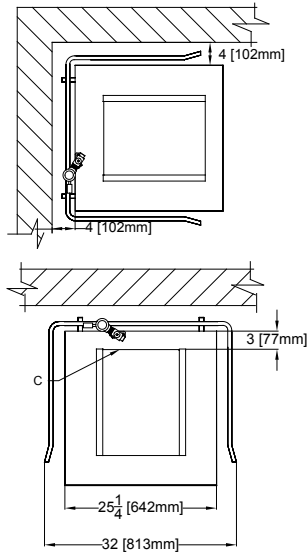

LEGEND  
 A - DRAIN 1/2" NPT  
 B - WATER INLET 1/2" NPT  
 C - ELECTRICAL CONNECTION  
 D - OUTLET TO BOOSTER HEATER 3/4" NPT  
 E - INLET FROM BOOSTER HEATER 3/4" NPT

All vertical dimensions are +/- 1/2" due to adjustable bullet feet.

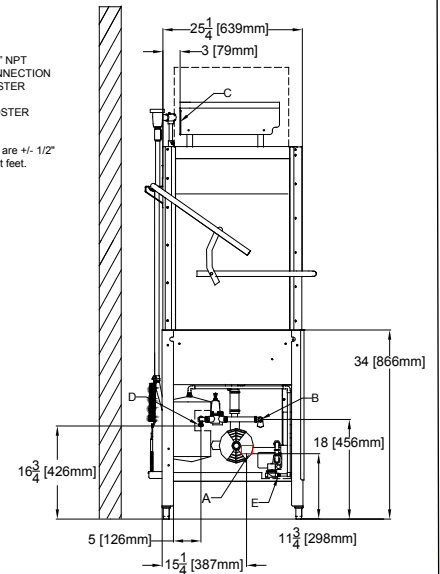

DIMENSIONS--STANDARD MODEL

MODEL NO.	SIZE			DRAIN HEIGHT	SHIPPING INFO			DIMENSIONS		
	HEIGHT	WIDTH	DEPTH		WEIGHT	CLASS	CUBE	HEIGHT	WIDTH	DEPTH
TempStar™ HH/GPX	76-3/4" (1949 mm)	25-1/4" (641 mm)	25-1/4" (641 mm)	11-3/4" (298 mm)	420 lbs (191 kg)	92.5	71.4 cu. ft.	85" (2159 mm)	44" (1118 mm)	33" (838 mm)

DIMENSION REQUIREMENTS

Minimum Ceiling Height (Recommended)	88" / (2 meters)
Wall Clearance (Minimum)	4" / (102 mm)
Standard Table Height	34" / (864 mm)
Inside Clearance	17-1/4" / (438 mm)

GAS REQUIREMENTS

	Maximum	Minimum
Natural Gas (Inches-water column)	10.5 / (267 mm)	5.0 / (127 mm)
LP Propane Gas (Inches-water column)	13.0 / (330 mm)	11.0 / 292 mm)
Gas Booster Capacity (BTU)		
Input		105,000
Output		84,800

OPERATING CAPACITY

Racks per Hour	Normal 53	Medium 28	Heavy 19	Extra Heavy 11
OPERATING CYCLE (sec)	Wash	Rinse	Dwell	Total Cycle
Normal	45	15	2	62
Medium	103	15	2	120
Heavy	163	15	2	180
Extra Heavy	283	15	2	300

OPERATING TEMPERATURES

Wash (Minimum)	150°F / (66°C)
Rinse (Minimum)	180°F / (82°C)

WASH PUMP MOTOR

Wash Pump Motor Horsepower	2 HP
----------------------------	------

WATER REQUIREMENTS

Inlet Temperature	
40°F / (4°C) Rise	140°F / (82°C)
70°F / (21°C) Rise	110°F / (60°C)
Gallons per hour	72.1 / 273 Ltr.
Waterline Size IPS (Minimum-inches)	3/4
Drainline Size IPS (Minimum-Inches)	1-1/2
Flow Pressure (PSI)	15-25
Tank Capacity	
Wash Tank	8 Gal. / (30 ltr)
Booster Tank	3 Gal. / (11 ltr)
Pump Capacity (GPM)	73 Gal / (276 ltr)

APPROXIMATE TOTAL LOAD AMPS

	AMPS
115V/60HZ/1PH	25
208V/60HZ/1PH	13
230V/60HZ/3PH	13
230V/60HZ/1PH	13
230V/60HZ/3PH	13

How To Specify - TempStar™ HH/GPX

Highway 25E  
 P. O. Box 1060  
 Barbourville, KY 40906

Tel: 606-523-9795  
 Tel: 1-888-800-5672  
 Fax: 606-523-9196

E-mail: [info@jacksonmsc.com](mailto:info@jacksonmsc.com)

[www.jacksonmsc.com](http://www.jacksonmsc.com)  
 07610-002-66-62 (09/07)